

# It's SIMD All Over Again! \*

By

Doug McCowan and Vladimir Bashkardin

Bureau of Economic Geology  
University of Texas

\* with apologies to Yogi Berra

## Abstract

The SIMD style of parallel computing, where many processors execute the same instruction but on different data, flourished back in the days of the Connection Machine and Maspar supercomputers. However, the advent of commodity PC cluster computing, which is actually a kind of MIMD computing, effectively ended it. Now it's back! The commercial appearance of General Purpose **Graphics** Programming Units (GPGPUs) which are SIMD machines means that, once again, we must seek SIMD algorithms to solve scientific problems on this hardware. Since nature is SIMD, there is substantial hope that this will be a successful quest. We must realize, however, that these new SIMD algorithms may be quite different from those already in use and possibly less efficient.

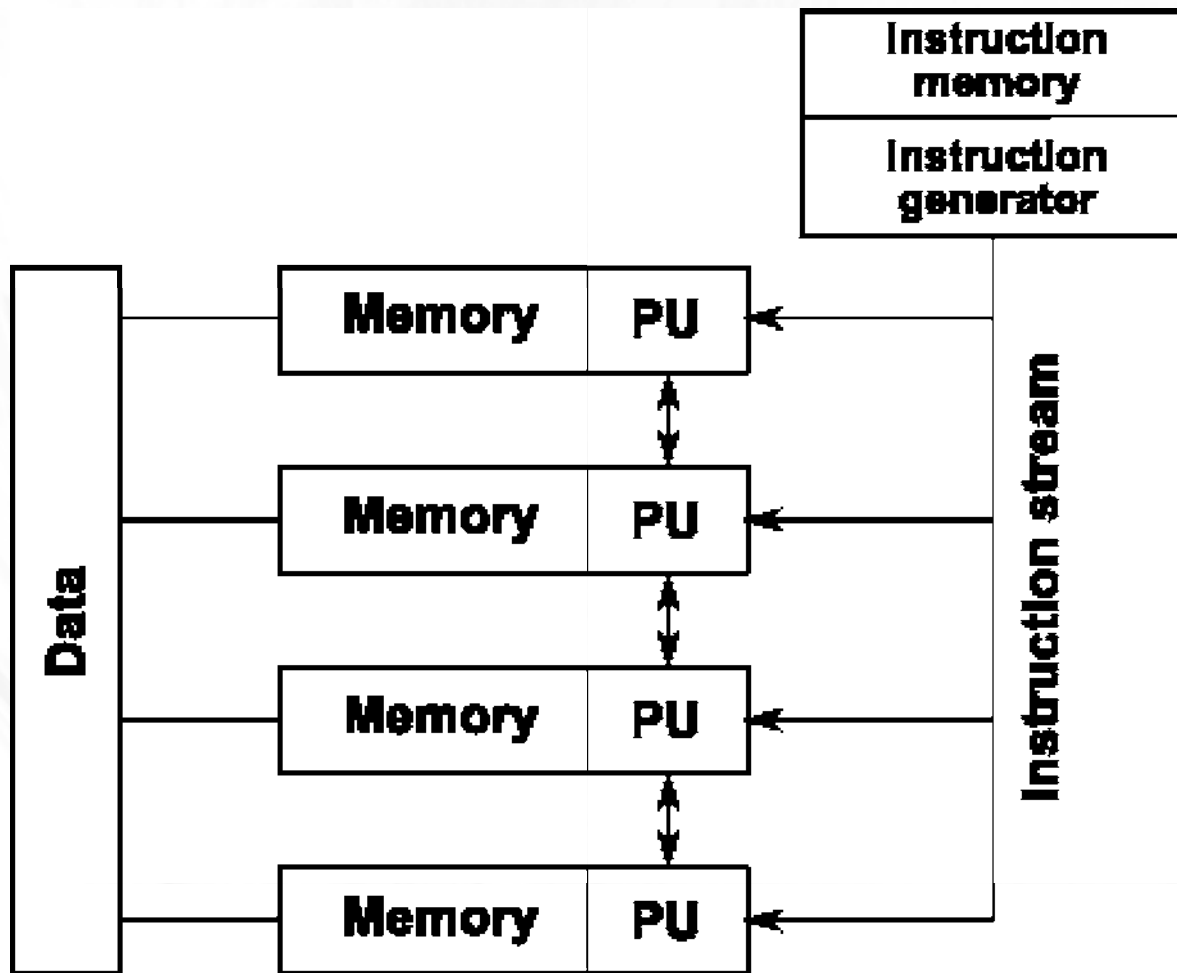

SIMD Computer Configuration

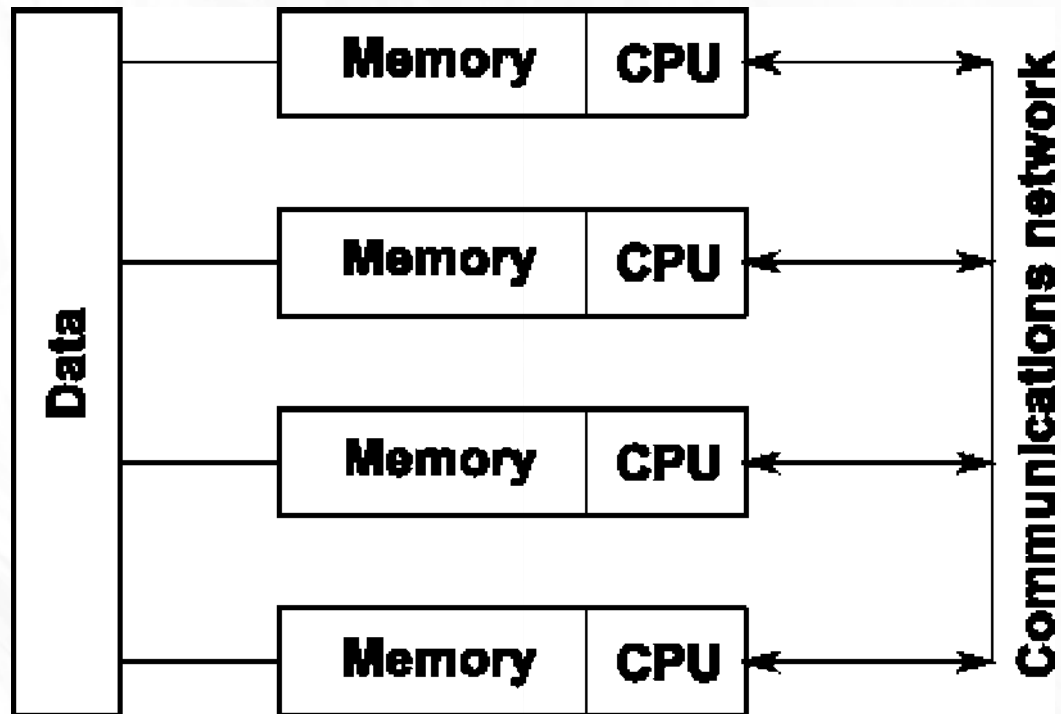

MIMD Computer Configuration

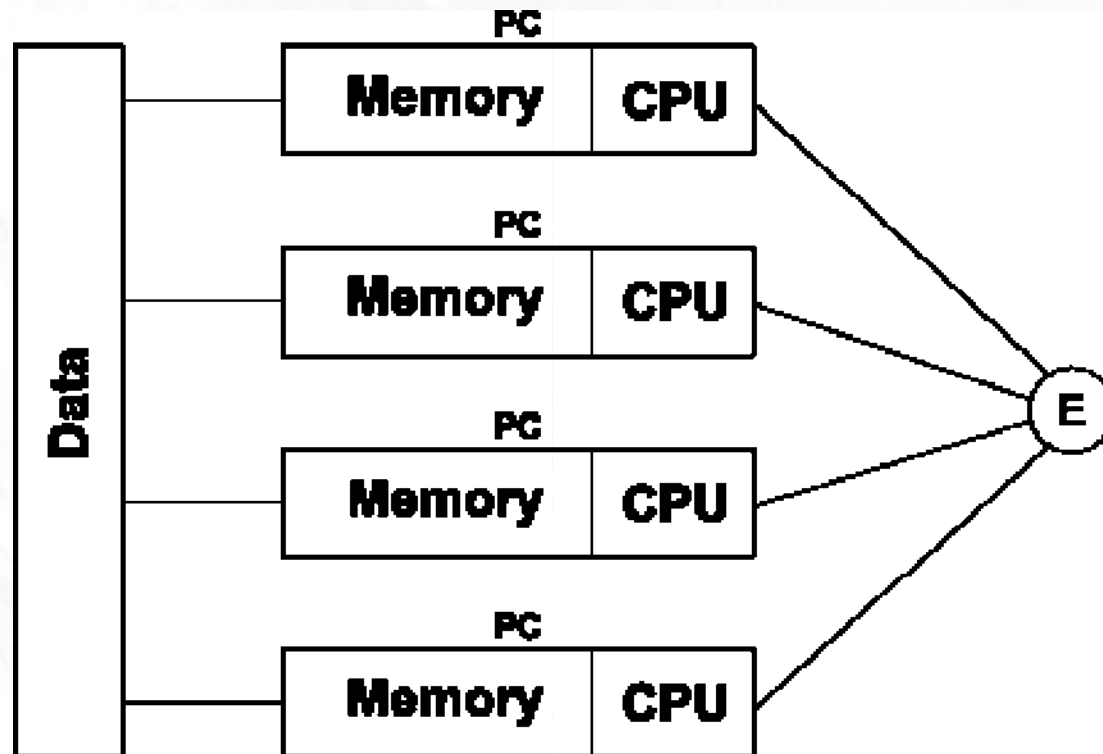

Cluster Computer Configuration

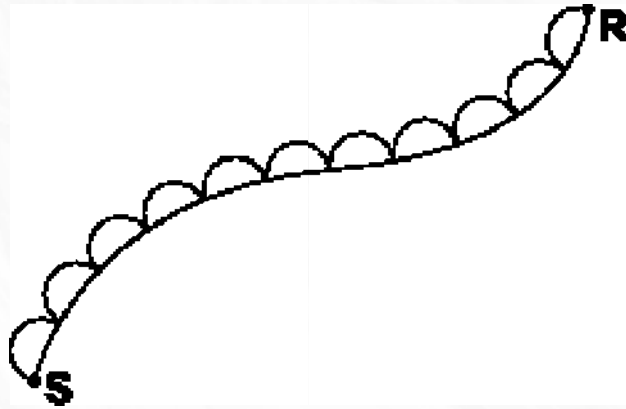

Propagation of Light from Source to Receiver

$$|\text{deIT}| = 1/c$$

Eikonal (O'Connell) Equation

$$TT_i = \min(TT_j + TT_{ij}) \quad j = \text{neighbor of } i$$

$$TT_{ij} = d_{ij} * (s_i + s_j) / 2$$

Bellman's Equations

$T|_{t_s} = 0$  at source

$T|_{t_i} = \text{inf.}$  not at source

**Initial Conditions**

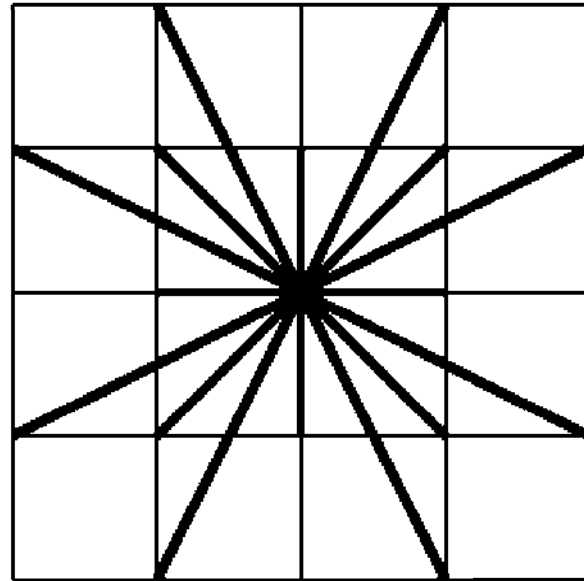

2D 16 Nearest Neighbor Case

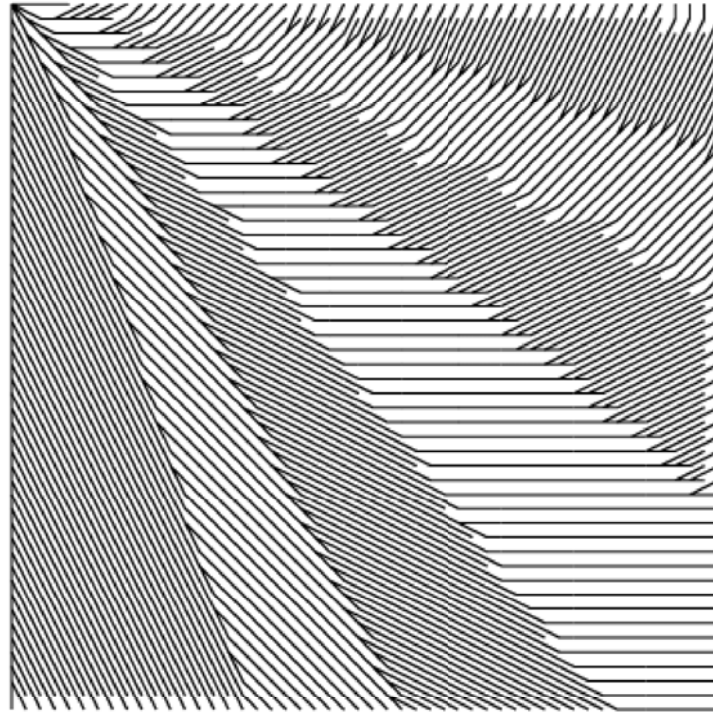

2D Raytrace in linear velocity increase

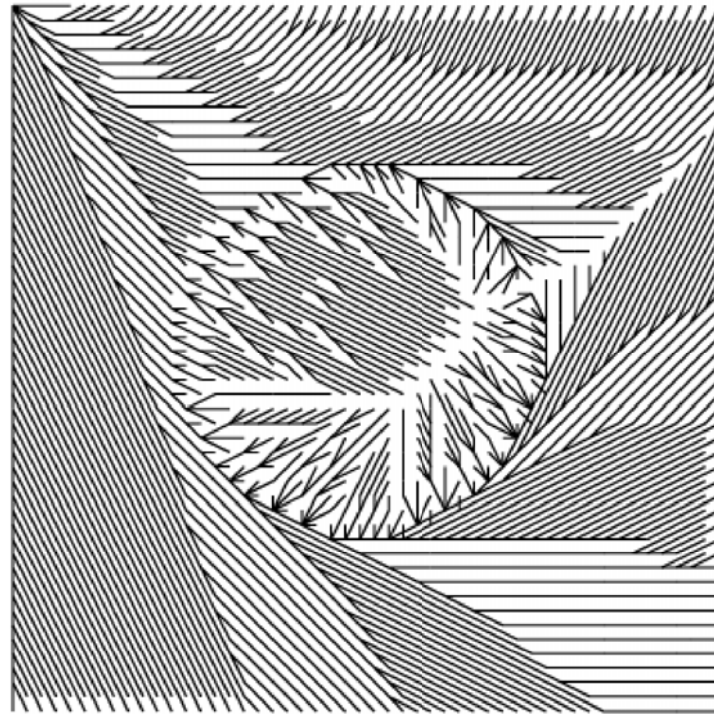

2D raytrace in a linear velocity increase  
medium with constant velocity inclusion

The future's the hardest thing to predict!

Yogi Berra